

BSR/ASHRAE Addendum e
to ANSI/ASHRAE Standard 135.1-2007

Public Review Draft

ASHRAE® Standard

Proposed Addendum e to Standard 135.1-2007, *Method of Test for Conformance to BACnet®*

First Public Review (March 2009)
(Draft Shows Proposed Changes to
Current Standard)

This draft has been recommended for public review by the responsible project committee. To submit a comment on this proposed addendum, go to the ASHRAE website at <http://www.ashrae.org/technology/page/331> and access the online comment database. The draft is subject to modification until it is approved for publication by the Board of Directors and ANSI. Until this time, the current edition of the standard (as modified by any published addenda on the ASHRAE web site) remains in effect. The current edition of any standard may be purchased from the ASHRAE Bookstore @ <http://www.ashrae.org> or by calling 404-636-8400 or 1-800-527-4723 (for orders in the U.S. or Canada).

This standard is under continuous maintenance. To propose a change to the current standard, use the change submittal form available on the ASHRAE web site @ <http://www.ashrae.org>.

The appearance of any technical data or editorial material in this public review document does not constitute endorsement, warranty, or guaranty by ASHRAE of any product, service, process, procedure, or design, and ASHRAE expressly disclaims such.

© March 20, 2009. This draft is covered under ASHRAE copyright. Permission to reproduce or redistribute all or any part of this document must be obtained from the ASHRAE Manager of Standards, 1791 Tullie Circle, NE, Atlanta, GA 30329-2305. Phone: 404-636-8400, Ext1125. Fax: 404-321-5478. E-mail: standards.section@ashrae.org.

AMERICAN SOCIETY OF HEATING,
REFRIGERATING AND AIR-CONDITIONING
ENGINEERS, INC.
1791 Tullie Circle, NE · Atlanta GA 30329-2305

[This foreword and the “rationale” on the following page are not part of this standard. They are merely informative and do not contain requirements necessary for conformance to the standard.]

FOREWORD

The purpose of this addendum is to present a proposed change for public review. These modifications are the result of change proposals made pursuant to the ASHRAE continuous maintenance procedures and of deliberations within Standing Standard Project Committee 135. The proposed changes are summarized below.

135.1-2007~~e~~-1. Revise BACnet/IP tests, p. 1.

In the following document, language to be added to existing clauses of ANSI/ASHRAE 135.1-2007 and Addenda is indicated through the use of *italics*, while deletions are indicated by ~~striketrough~~. Where entirely new subclauses are proposed to be added, plain type is used throughout. Only this new and deleted text is open to comment as this time. All other material in this addendum is provided for context only and is not open for public review comment except as it relates to the proposed changes.

135.1-2007e-1. Revise BACnet/IP tests.

Rationale

The BBMD BACnet/IP tests in 135.1-2007 were written for the one-hop method for distribution of broadcasts. As one-hop distribution is not practical over the Internet, two-hop distribution is the method most used and therefore tested. Many tests specified fixed IP addresses and subnet masks, which resulted in inflexibility for the tester. Other tests have had minor errors and omissions corrected in them. Functionality such as a non-BBMD device operating as a foreign device and a BBMD-device with a server application did not have tests. This change also resolves the ambiguity regarding the grace period and remaining time in foreign device registrations.

Addendum 135.1-2007e-1

[Change Clause **14.1.7**, p. 461]

[Reason for Change: The original test specified a unicast message in step 1, which is incorrect for a Forwarded-NPDU on an IP subnet. The Originating-Device is specified. Also, step 3 now specifies clearly what the IUT is not to do.]

14.1.7 Forwarded-NPDU (One-hop Distribution)

Purpose: To verify that an IUT, not configured as a BBMD, will process a Forwarded-NPDU message.

Configuration Requirements: The IUT shall not be configured as a BBMD. The TD shall be on a different IP subnet than that of the IUT.

Test Steps:

1. TRANSMIT DESTINATION = ~~IUT LOCAL BROADCAST~~, SOURCE = TD,
Forwarded-NPDU,
Originating-Device = TD,
NPDU = Who-Is
2. RECEIVE DESTINATION = ~~Local IP Broadcast~~ LOCAL BROADCAST, SOURCE = IUT,
Original-Broadcast-NPDU,
NPDU = I-Am
3. CHECK (The IUT shall not ~~take any additional action~~ issue any Forwarded-NPDUs)

[Add new Clause **14.1.X**, p. 462]

[Reason for Change: No relevant test exists in 135.1 to test this functionality]

14.1.X Forwarded-NPDU (Two-hop Distribution)

Purpose: To verify that an IUT, not configured as a BBMD, will process a Forwarded-NPDU message.

Configuration Requirements: The IUT should not be configured as a BBMD. The TD shall be on the same subnet as the IUT. D1 is a device on a different IP subnet than the TD.

Test Steps:

1. TRANSMIT DESTINATION = LOCAL BROADCAST, SOURCE = TD,
Forwarded-NPDU,
Originating-Device = D1,
NPDU = Who-Is
2. RECEIVE DESTINATION = LOCAL BROADCAST, SOURCE = IUT,
Original-Broadcast-NPDU,
NPDU = I-Am

3. CHECK (The IUT shall not issue any Forwarded-NPDUs)

[Change Clause **14.1.8**, p. 461]

[Reason for Change: The original test specified a unicast message in step 1, which is incorrect for a Original-Broadcast-NPDU on an IP subnet. Also, step 3 now specifies clearly what the IUT is not to do.]

14.1.8 Original-Broadcast-NPDU

Purpose: To verify that an IUT, not configured as a BBMD, will process an Original-Broadcast-NPDU message.

Test Steps:

1. TRANSMIT DESTINATION = ~~IUT~~ LOCAL BROADCAST, SOURCE = TD,
Original-Broadcast-NPDU,
NPDU = Who-Is
2. RECEIVE DESTINATION = = ~~Local IP Broadcast~~ LOCAL BROADCAST, SOURCE = IUT,
Original-Broadcast-NPDU,
NPDU = I-Am
3. CHECK (The IUT shall not ~~take any additional action~~ issue any Forwarded-NPDUs)

[Change Clause **14.1.9**, p. 461]

[Reason for Change: The original test specified the source as D1 in step 1. D1 is not defined.]

14.1.9 Original-Unicast-NPDU

Purpose: To verify that an IUT, not configured as a BBMD, will process an Original-Unicast-NPDU message.

Test Steps:

1. TRANSMIT DESTINATION = IUT, SOURCE = ~~D1~~TD,
Original-Unicast-NPDU,
NPDU = BACnet ReadProperty-Request
2. RECEIVE DESTINATION = TD, SOURCE = IUT,
Original-Unicast-NPDU,
NPDU = ReadProperty-ACK

[Change Clause **14.2**, p. 462]

[Reason for Change: Originally these tests were for non-BBMD Devices. It was recognized that a test for a BBMD device with a server application was also needed, so these tests were expanded to include both non-BBMD devices and BBMD devices. Because the non-BBMD tests in this section duplicate the tests 14.1.7, 14.1.8, and 14.1.9, they were removed from this section. This resulted in these tests being exclusively for BBMD devices. BBMD tests were modified to reference Figure 14-1. This was done to enable the tester to choose IP address and subnet mask settings as appropriate and to clarify the role of the TD in each test.]

14.2 ~~Non-BBMD B/IP device~~ Device with a Server Application

This group of tests verifies that a *BBMD B/IP device that is not a BBMD* with a server application will correctly process NPDU's conveyed in the NPDU portion of Forwarded-NPDU, Original-Broadcast-NPDU and Original-Unicast-NPDU messages.

~~Configuration Requirements: Before this group of tests is performed, the IUT shall be configured so that the BBMD option is off. The IUT shall be made to go through its startup procedure. A server application shall be running.~~
Configuration Requirements: A server application shall be running in the IUT. For one-hop distribution tests the Internet Routers in Figure 14-1 must be configured to forward directed broadcasts.

Notes to Tester: Figure 14-1 shows the logical network configuration for tests 14.2 – 14.7. The complete network is not required for the tests, so long as the IUT can receive packets formed as though they arrived from the specified device. The role of the TD when executing the TRANSMIT statement in each test is specified. The TD must also monitor the IUT’s subnet throughout all tests and RECEIVE shall mean from the IUT’s subnet. To accomplish this, the TD may be multi-homed or another TD can be used to monitor the IUT’s subnet.

The term Local IP Broadcast means that the host portion of the destination IP addresses is all 1’s and the MAC layer destination address is also a broadcast. The term Directed IP Broadcast means that the host portion of the destination IP address is all 1’s and the MAC layer destination address is equal to the routers MAC address. The host portion of the IP address is those bits that are 0 in the subnet mask. The tester shall choose appropriate IP addresses and subnet masks for each of the devices.

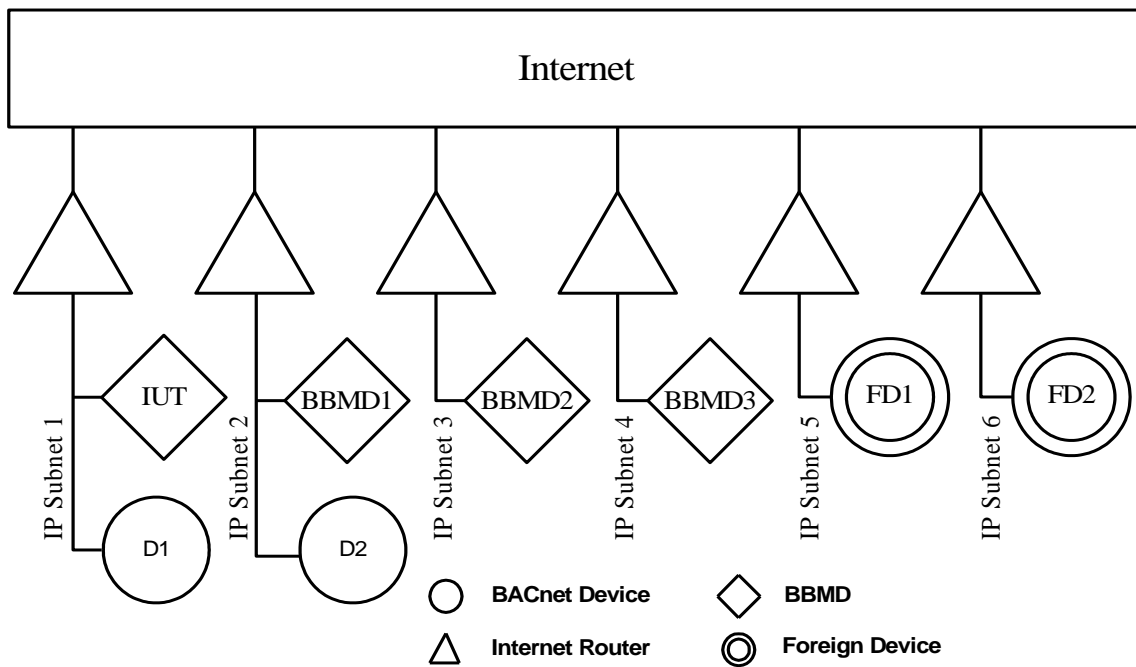

Figure 14-1. Logical network configuration for BBMD tests.

[Change Clause 14.2.1, p. 462]

14.2.1 Execute Forwarded-NPDU

Purpose: To verify that the IUT, ~~not configured as a BBMD,~~ will pass a Forwarded-NPDU message to its Application Entity.

~~Configuration Requirements: The TD shall be configured so that SNET/SADR fields in the Network Layer header shall not be present in step 1.~~

Test Steps:

1. TRANSMIT DESTINATION = IUT, SOURCE = TD,
 — Forwarded NPDU,

- ~~NPDU = Who-Is~~
- 2. ~~RECEIVE DESTINATION = Local IP Broadcast, SOURCE = IUT,~~
- ~~Original Broadcast NPDU,~~
- ~~NPDU = I-Am~~

Configuration Requirements: The TD shall take the role of BBMD1. DNET/DADR and SNET/SADR fields in the Network Layer header shall not be present in step 1.

This test is broken into separate tests for one-hop distribution and two-hop distribution.

14.2.1.1 Execute Forwarded-NPDU (One-hop Distribution)

Configuration Requirements: The IUT shall be configured with a BDT that contains:

<i>B/IP Address</i>	<i>Broadcast Distribution Mask</i>
<i>IUT</i>	<i>IP Subnet 1 subnet mask</i>
<i>BBMD1</i>	<i>IP Subnet 2 subnet mask</i>

Test Steps:

1. **TRANSMIT**
*DA = Directed IP Broadcast to IP Subnet 1,
 SA = BBMD1,
 Forwarded-NPDU,
 Originating-Device = BBMD1,
 NPDU = Who-Is*
2. **RECEIVE**
*DA = Local IP Broadcast on IP Subnet 1,
 SA = IUT,
 Original-Broadcast-NPDU,
 NPDU = I-Am*
3. **RECEIVE**
*DA = Directed IP Broadcast to IP Subnet 2,
 SA = IUT,
 Forwarded-NPDU,
 Originating-Device = IUT,
 NPDU = I-Am*
4. **CHECK** *(The IUT does not forward or resend the Who-Is packet out the port on which it was received)*

Notes to Tester: The order of the messages transmitted by the IUT is not significant.

14.2.1.2 Execute Forwarded-NPDU (Two-hop Distribution)

Configuration Requirements: The IUT shall be configured with a BDT that contains:

<i>B/IP Address</i>	<i>Broadcast Distribution Mask</i>
<i>IUT</i>	<i>255.255.255.255</i>
<i>BBMD1</i>	<i>255.255.255.255</i>

Test Steps:

1. **TRANSMIT**
*DA = IUT,
 SA = BBMD1,
 Forwarded-NPDU,
 Originating-Device = BBMD1,
 NPDU = Who-Is*
2. **RECEIVE**

*DA = Local IP Broadcast on IP Subnet 1,
 SA = IUT,
 Forwarded-NPDU,
 Originating-Device = BBMD1,
 NPDU = Who-Is*

3. RECEIVE

*DA = Local IP Broadcast on IP Subnet 1,
 SA = IUT,
 Original-Broadcast-NPDU,
 NPDU = I-Am*

4. RECEIVE

*DA = BBMD1,
 SA = IUT,
 Forwarded-NPDU,
 Originating-Device = IUT,
 NPDU = I-Am*

Notes to Tester: The order of the messages transmitted by the IUT is not significant.

[Change Clause **14.2.2**, p. 462]

14.2.2 Execute Original-Broadcast-NPDU

Purpose: To verify that the IUT, ~~not configured as a BBMD~~, will pass an Original-Broadcast-NPDU message to its Application Entity.

~~Configuration Requirements: DNET/DADR and SNET/SADR fields in the Network Layer header shall not be present in step 1.~~

~~Test Steps:~~

- ~~1. TRANSMIT DESTINATION = IUT, SOURCE = TD,
 — Original Broadcast NPDU,
 — NPDU = Who-Is~~
- ~~2. RECEIVE DESTINATION = TD, SOURCE = IUT,
 — Original Broadcast NPDU,
 — NPDU = I Am~~

Configuration Requirements: The TD shall take the role of device D1. DNET/DADR and SNET/SADR fields in the Network Layer header shall not be present in step 1.

This test is broken into separate tests for one-hop distribution and two-hop distribution.

14.2.2.1 Execute Original-Broadcast-NPDU (One-hop Distribution)

Configuration Requirements: The IUT shall be configured with a BDT that contains:

<i>B/IP Address</i>	<i>Broadcast Distribution Mask</i>
<i>IUT</i>	<i>IP Subnet 1 subnet mask</i>
<i>BBMD1</i>	<i>IP Subnet 2 subnet mask</i>

Test Steps:

1. TRANSMIT
 DA = Local IP Broadcast,
 SA = D1,
 Original-Broadcast-NPDU,
 NPDU = Who-Is
2. RECEIVE
 DA = Directed IP Broadcast to IP Subnet 2,
 SA = IUT,
 Forwarded-NPDU,
 Originating-Device = D1,
 NPDU = Who-Is
3. RECEIVE
 DA = Local IP Broadcast,
 SA = IUT,
 Original-Broadcast-NPDU,
 NPDU = I-Am
4. RECEIVE
 DA = Directed IP Broadcast to IP Subnet 2,
 SA = IUT,
 Forwarded-NPDU,
 Originating-Device = IUT,
 NPDU = I-Am

Notes to Tester: The order of the messages transmitted by the IUT is not significant.

14.2.2.2 Execute Original-Broadcast-NPDU (Two-hop Distribution)

Configuration Requirements: The IUT shall be configured with a BDT that contains:

<i>B/IP Address</i>	<i>Broadcast Distribution Mask</i>
<i>IUT</i>	<i>255.255.255.255</i>
<i>BBMD1</i>	<i>255.255.255.255</i>

Test Steps:

1. TRANSMIT
 DA = Local IP Broadcast,
 SA = D1,
 Original-Broadcast-NPDU,
 NPDU = Who-Is
2. RECEIVE
 DA = BBMD1,
 SA = IUT,
 Forwarded-NPDU,
 Originating-Device = D1,
 NPDU = Who-Is
3. RECEIVE
 DA = Local IP Broadcast,
 SA = IUT,
 Original-Broadcast-NPDU,
 NPDU = I-Am
4. RECEIVE
 DA=BBMD1,

SA=IUT,
 Forwarded-NPDU,
 Originating-Device = IUT,
 NPDU = I-Am

Notes to Tester: The order of the messages transmitted by the IUT is not significant.

[Change Clause 14.2.3, p. 462]

14.2.3 Execute Original-Unicast-NPDU

Purpose: To verify that the IUT, ~~not configured as a BBMD,~~ will pass ~~a~~*an* Original-Unicast-NPDU message to its Application Entity.

~~Configuration Requirements: DNET/DADR and SNET/SADR fields in the Network Layer header shall not be present in step 1.~~

~~Test Steps:~~

- ~~1. TRANSMIT DESTINATION = IUT, SOURCE = TD,
 — Original Unicast NPDU,
 — NPDU = Read Property~~
- ~~2. RECEIVE DESTINATION = TD, SOURCE = IUT,
 — Original Unicast NPDU,
 — NPDU = Read Property Ack~~

~~Configuration Requirements: The TD shall take the role of device D1. DNET/DADR and SNET/SADR fields in the Network Layer header shall not be present in step 1. The IUT shall be configured with a BDT that contains:~~

B/IP Address	Broadcast Distribution Mask
IUT	255.255.255.255
BBMD1	255.255.255.255

~~Test Steps:~~

1. TRANSMIT
 - DA = IUT,
 - SA = D1,
 - Original-Unicast-NPDU,
 - NPDU = Read-Property
2. RECEIVE
 - DA = D1,
 - SA = IUT,
 - Original-Unicast-NPDU,
 - NPDU = Read-Property-Ack
3. CHECK (The IUT does not forward to BBMD1 either packet from step 1 or step 2)

[Change Clause 14.3, p. 463]

14.3 Broadcast Distribution Table Operations

[Reason for Change: The original tests were designed for one-hop distribution. As the BTL made one-hop distribution optional, these tests were modified for two-hop distribution. The tests were modified to reference figure 14-1 to be consistent with all the BBMD tests.]

This group of tests verifies that a BACnet Broadcast Management Device ~~without a FDT~~ will correctly perform BDT operations.

~~Configuration Requirements: Before this group of tests is performed, the IUT shall be configured so that BBMD option is on, FDT option is off. BDT shall contain two entries:~~

B/IP Address	Label	Subnet Mask
123.4.5.6: 0xBAC0	IUT	255.0.0.0
123.7.8.10: 0xBAC4		255.255.0.0

~~Configuration Requirements: The TD shall take the role of device D1. The IUT shall be configured with a BDT that contains:~~

B/IP Address	Broadcast Distribution Mask
IUT	255.255.255.255
BBMD1	255.255.255.255

The IUT shall be made to go through its startup procedure. ~~No applications shall be running.~~

[Change Clause 14.3.1, p. 463]

14.3.1 ~~Startup Configuring of the Broadcast Distribution Table~~ *Execute Write-Broadcast-Distribution-Table (Table Growth)*

Purpose: To verify that the IUT, configured as a BBMD, will ~~configure its Broadcast Distribution Table during the initialization procedure.~~ *execute a Write-Broadcast-Distribution-Table request when the new table is greater than the current table.*

Configuration Requirements: The IUT is configured as required in 14.3.

Test Steps:

1. TRANSMIT DESTINATION = IUT, SOURCE = TD,
— Read Broadcast Distribution Table
 2. RECEIVE DESTINATION = TD, SOURCE = IUT,
— Read Broadcast Distribution Table Ack,
— List of BDT Entries
 3. CHECK (List of BDT Entries consisting of two entries (order unspecified))

(123.4.5.6: 0xBAC0)	255.0.0.0
(123.7.8.10: 0xBAC4)	255.255.0.0
-

Test Steps:

1. TRANSMIT
 - DA = IUT,
 - SA = D1,
 - Write-Broadcast-Distribution-Table,
 - (List of BDT Entries consisting of

BBMD1	255.255.255.255
BBMD2	255.255.255.255
BBMD3	255.255.255.255
IUT	255.255.255.255
2. RECEIVE
 - DA = D1,

- SA = IUT,
 BVLC-Result message,
 'Result Code' = Successful completion
3. TRANSMIT
 - DA = IUT,
 - SA = DI,
 - Read-Broadcast-Distribution-Table
 4. RECEIVE
 - DA = DI,
 - SA = IUT,
 - Read-Broadcast-Distribution-Table-Ack,
 - List of BDT Entries
 5. CHECK (List of BDT Entries consisting of four entries (order unspecified))

BBMD1	255.255.255.255
BBMD2	255.255.255.255
BBMD3	255.255.255.255
IUT	255.255.255.255
-)

[Change Clause 14.3.2, p. 463]

14.3.2 Execute Write-Broadcast-Distribution-Table (Table Growth Shrinkage)

Purpose: To verify that the IUT, configured as a BBMD, will execute Write-Broadcast-Distribution-Table request when new table is ~~greater~~ smaller than the current ~~one~~-table. Also, this test verifies that IUT will correctly identify itself in the table being written.

Test Steps:

1. TRANSMIT DESTINATION = IUT, SOURCE = TD,
 - Write Broadcast Distribution Table,
 - (List of BDT Entries consisting of

(123.4.5.6: 0xBAC0)	255.0.0.0
(123.7.8.9: 0xBAC4)	255.0.0.0
(123.7.8.9: 0xBAC5)	255.255.0.0
(123.7.8.9: 0xBAC6)	255.255.255.0
- >
2. RECEIVE DESTINATION = TD, SOURCE = IUT,
 - BVLC Result message,
 - 'Result Code' = 0
3. TRANSMIT DESTINATION = IUT, SOURCE = TD,
 - Read Broadcast Distribution Table
4. RECEIVE DESTINATION = TD, SOURCE = IUT,
 - Read Broadcast Distribution Table Ack,
 - List of BDT Entries
5. CHECK (List of BDT Entries consisting of four entries (order unspecified))

(123.4.5.6: 0xBAC0)	255.0.0.0
(123.7.8.9: 0xBAC4)	255.0.0.0
(123.7.8.9: 0xBAC5)	255.255.0.0
(123.7.8.9: 0xBAC6)	255.255.255.0
- >

Configuration Requirements: The IUT's BDT has a minimum of four entries.

Test Steps:

1. TRANSMIT
 - DA = IUT,
 - SA = DI,
 - Write-Broadcast-Distribution-Table,
 - (List of BDT entries consisting of three entries

BBMD2	255.255.255.255
BBMD3	255.255.255.255
IUT	255.255.255.255
-)
2. RECEIVE
 - DA = DI,
 - SA = IUT,
 - BVLC-Result,
 - 'Result Code' = Successful completion
3. TRANSMIT
 - DA = IUT,
 - SA = DI,
 - Read-Broadcast-Distribution-Table
4. RECEIVE
 - DA = DI,
 - SA = IUT,
 - Read-Broadcast-Distribution-Table-Ack,
 - List of BDT entries
5. CHECK (List of BDT entries consisting of three entries (order unspecified))

BBMD2	255.255.255.255
BBMD3	255.255.255.255
IUT	255.255.255.255
-)

[Change Clause 14.3.3, p. 464]

14.3.3 — ~~Execute Write Broadcast Distribution Table (Table Shrinkage)~~

~~Purpose: To verify that the IUT, configured as a BBMD, will execute Write Broadcast Distribution Table request when new table is smaller than the current table. Also, this test verifies that IUT will correctly identify itself in the table being written.~~

Test Steps:

1. TRANSMIT DESTINATION = IUT, SOURCE = TD,
 - ~~Write Broadcast Distribution Table,~~
 - ~~(List of BDT entries consisting of three entries~~

(123.7.8.9: 0xBAC4)	255.0.0.0
(123.4.5.6: 0xBAC0)	255.0.0.0
(123.7.8.9: 0xBAC5)	255.255.0.0
- ~~)~~
2. RECEIVE DESTINATION = TD, SOURCE = IUT,
 - ~~BVLC Result,~~
 - ~~'Result Code' = 0~~
3. TRANSMIT DESTINATION = IUT, SOURCE = TD,
 - ~~Read Broadcast Distribution Table~~
4. RECEIVE DESTINATION = TD, SOURCE = IUT,
 - ~~Read Broadcast Distribution Table Ack,~~
 - ~~List of BDT entries~~
5. CHECK (List of BDT entries consisting of three entries (order unspecified))

(123.4.5.6: 0xBAC0)	255.0.0.0
---------------------	-----------

(123.7.8.9: 0xBAC4) 255.0.0.0
 (123.7.8.9: 0xBAC5) 255.255.0.0

→

14.3.3 Verify Broadcast Distribution Table Created from the Configuration Saved During the Previous Session

Purpose: To verify that a BBMD will update the BDT in the local configuration database and initialize it at startup.

Configuration Requirements: The IUT's BDT does not consist of the same entries as are written in step 1.

Test Steps:

1. TRANSMIT
 - DA = IUT,
 - SA = DI,
 - Write-Broadcast-Distribution-Table,
 - (List of BDT entries consisting of three entries
 - IUT 255.255.255.255
 - BBMD1 255.255.255.255
 - BBMD2 255.255.255.255
 -)
2. RECEIVE
 - DA = DI,
 - SA = IUT,
 - BVLC-Result,
 - 'Result Code' = Successful completion
3. WAIT (Vendor specified period for BDT to be saved in non-volatile memory)
4. MAKE (the IUT reset)
5. TRANSMIT
 - DA = IUT,
 - SA = DI,
 - Read-Broadcast-Distribution-Table
6. RECEIVE
 - DA = DI,
 - SA = IUT,
 - Read-Broadcast-Distribution-Table-Ack,
 - List of BDT Entries
7. CHECK (List of BDT Entries consisting of three entries (order unspecified)
 - IUT 255.255.255.255
 - BBMD1 255.255.255.255
 - BBMD2 255.255.255.255
 -)

[Change Clause 14.5.2, p. 467]

[Reason for Change: The original tests were designed for one-hop distribution. A two-hop distribution version of the test was added. The test was modified to include a BDT with 4 entries, rather than 3, as this is the minimum the BTL requires. The tests were modified to reference figure 14-1 to be consistent with all the BBMD tests.]

14.5.2 Original-Broadcast-NPDU Message Which Shall Be Forwarded

Purpose: To verify that the IUT, configured as a BBMD without an FDT or with an empty FDT, will handle an Original-Broadcast-NPDU message.

Test Steps:

1. TRANSMIT DESTINATION = IUT, SOURCE = TD,
~~Original Broadcast NPDU,
 NPDU = Who-Is~~
2. RECEIVE DESTINATION = (123.255.255.255, 0xBAC4), SOURCE = IUT,
~~Forwarded NPDU,
 NPDU = Who-Is~~
3. RECEIVE DESTINATION = (123.7.255.255, 0xBAC5), SOURCE = IUT,
~~Forwarded NPDU,
 NPDU = Who-Is~~

Configuration Requirements: The TD shall take the role of device D1 on the IUT's subnet. DNET/DADR and SNET/SADR fields in the Network Layer header shall not be present in step 1.

This test is broken into separate tests for one-hop distribution and two-hop distribution.

14.5.2.1 Original-Broadcast-NPDU Message Which Shall Be Forwarded (One-hop Distribution)

Configuration Requirements: The IUT shall be configured with a BDT that contains:

<i>B/IP Address</i>	<i>Broadcast Distribution Mask</i>
<i>IUT</i>	<i>IP Subnet 1 subnet mask</i>
<i>BBMD1</i>	<i>IP Subnet 2 subnet mask</i>
<i>BBMD2</i>	<i>IP Subnet 3 subnet mask</i>
<i>BBMD3</i>	<i>IP Subnet 4 subnet mask</i>

Test Steps:

1. TRANSMIT
*DA = Local IP Broadcast,
 SA = D1,
 Original-Broadcast-NPDU,
 NPDU = Who-Is*
2. RECEIVE
*DA = Directed IP Broadcast to IP Subnet 2,
 SA = IUT,
 Forwarded-NPDU,
 Originating-Device = D1,
 NPDU = Who-Is*
3. RECEIVE
*DA = Directed IP Broadcast to IP Subnet 3,
 SA = IUT,
 Forwarded-NPDU,
 Originating-Device = D1,
 NPDU = Who-Is*
4. RECEIVE
*DA = Directed IP Broadcast to IP Subnet 4,
 SA = IUT,
 Forwarded-NPDU,
 Originating-Device = D1,
 NPDU = Who-Is*

Notes to Tester: The order of the messages transmitted by the IUT is not significant.

14.5.2.2 Original-Broadcast-NPDU Message Which Shall Be Forwarded (Two-hop Distribution)

Configuration Requirements: The IUT shall be configured with a BDT that contains:

<i>B/IP Address</i>	<i>Broadcast Distribution Mask</i>
<i>IUT</i>	<i>255.255.255.255</i>
<i>BBMD1</i>	<i>255.255.255.255</i>
<i>BBMD2</i>	<i>255.255.255.255</i>
<i>BBMD3</i>	<i>255.255.255.255</i>

Test Steps:

1. TRANSMIT
*DA = Local IP Broadcast,
 SA = D1,
 Original-Broadcast-NPDU,
 NPDU = Who-Is*
2. RECEIVE
*DA = BBMD1,
 SA = IUT,
 Forwarded-NPDU,
 Originating-Device = D1,
 NPDU = Who-Is*
3. RECEIVE
*DA = BBMD2,
 SA = IUT,
 Forwarded-NPDU,
 Originating-Device = D1,
 NPDU = Who-Is*
4. RECEIVE
*DA = BBMD3,
 SA = IUT,
 Forwarded-NPDU,
 Originating-Device = D1,
 NPDU = Who-Is*

Notes to Tester: The order of the messages transmitted by the IUT is not significant.

[Change Clause **14.6.2**, p. 468]

[Reason for Change: A draft of Annex J (BACnet/IP) contained text that allowed foreign devices to register for an indefinite period by sending a Register-Foreign-Device message with the Time-to-Live parameter value of zero to a BBMD. Indefinite (permanent) foreign device registration was removed from Annex J before it was published as an ASHRAE standard, but some tests in 135.1 still rely on indefinite foreign device registration]

14.6.2 Execute Permanent Foreign Device Registration

~~Purpose: To verify that the IUT will handle a Register-Foreign-Device-Table request when an infinite Time-To-Live value is supplied. There is no provision for permanent (indefinite) foreign device registration, so this test has been removed.~~

~~Test Steps:~~

- ~~1. TRANSMIT DESTINATION = IUT, SOURCE = FD1,
 — Register Foreign Device Table,
 — 'Time To Live' = 0~~
- ~~2. RECEIVE DESTINATION = FD1, SOURCE = IUT,~~

- BVLC Result,
- 'Result Code' = 0
- 3. TRANSMIT DESTINATION = IUT, SOURCE = TD,
— Read Foreign Device Table
- 4. RECEIVE, DESTINATION = TD, SOURCE = IUT,
— Read Foreign Device Table Ack,
 B/IP address of FD1, Time To Live = 0, Remaining Time = 0

[Change Clause **14.6.3**, p. 468]

[Reason for Change: References to Foreign Device registration for an indefinite time period were eliminated from the test. The ambiguity regarding the grace period and remaining time in foreign device registrations is resolved. The test was modified to reference figure 14-1 to be consistent with all of the BBMD tests.]

14.6.3 Foreign Device Table Timer Operations

Purpose: To verify that the IUT will handle FDT timer operations: finite time Foreign Device registration, re-registration, adding grace period to the supplied Time-To-Live parameter and FDT entry clearing upon timer expiration.

Test Steps:

1. TRANSMIT DESTINATION = IUT, SOURCE = FD2,
— Register Foreign Device Table,
— 'Time To Live' = 5
2. TRANSMIT DESTINATION = FD2, SOURCE = IUT,
— BVLC Result,
— 'Result Code' = 0
3. WAIT(10 seconds)
4. TRANSMIT DESTINATION = IUT, SOURCE = TD,
— Read Foreign Device Table
5. RECEIVE, DESTINATION = TD, SOURCE = IUT,
— Read Foreign Device Table Ack,
 B/IP address of FD1, Time To Live = 0, Remaining Time = 0
6. TRANSMIT DESTINATION = IUT, SOURCE = FD2,
— Register Foreign Device Table,
— 'Time To Live' = 20
7. TRANSMIT DESTINATION = FD2, SOURCE = IUT,
— BVLC Result,
— 'Result Code' = 0
8. WAIT(10 seconds)
9. TRANSMIT DESTINATION = IUT, SOURCE = TD,
— Read Foreign Device Table
10. RECEIVE, DESTINATION = TD, SOURCE = IUT,
— Read Foreign Device Table Ack,
 B/IP address of FD1, Time To Live = 0, Remaining Time = 0
 B/IP address of FD2, Time To Live = 20, Remaining Time = 10
11. WAIT(50 seconds)
12. TRANSMIT DESTINATION = IUT, SOURCE = TD,
— Read Foreign Device Table
13. RECEIVE, DESTINATION = TD, SOURCE = IUT,
— Read Foreign Device Table Ack,
 B/IP address of FD1, Time To Live = 0, Remaining Time = 0

Configuration Requirements: The TD shall take the role of foreign device FD2. The IUT's FDT must be empty.

Test Steps:

1. TRANSMIT
DA = IUT,
SA = FD2,
Register-Foreign-Device-Table,
'Time-To-Live' = 60
2. RECEIVE
DA = FD2,
SA = IUT,
BVLC-Result,
'Result Code' = 0
3. WAIT (10 seconds)
4. TRANSMIT
DA = IUT,
SA = FD2,
Read-Foreign-Device-Table
5. RECEIVE
DA = FD2,
SA = IUT,
Read-Foreign-Device-Table-Ack,
B/IP address of FD2, Time-To-Live = 60, Remaining-Time = 80
less test execution time
6. TRANSMIT
DA = IUT,
SA = FD2,
Register-Foreign-Device-Table,
'Time-To-Live' = 20
7. RECEIVE
DA = FD2,
SA = IUT,
BVLC-Result,
'Result Code' = 0
8. WAIT (30 seconds)
9. TRANSMIT
DA = IUT,
SA = FD2,
Read-Foreign-Device-Table
10. RECEIVE
DA = FD2,
SA = IUT,
Read-Foreign-Device-Table-Ack,
B/IP address of FD2, Time-To-Live = 20, Remaining-Time = 20
less test execution time
11. WAIT (30 seconds)
12. TRANSMIT
DA = IUT,
SA = FD2,
Read-Foreign-Device-Table
13. RECEIVE
DA = FD2,
SA = IUT,
Read-Foreign-Device-Table-Ack,
(No FDT entries)

[Change Clause **14.6.5**, p. 469]

[Reason for Change: The test was modified to reference figure 14-1 to be consistent with all the BBMD tests.]

14.6.5 Delete-Foreign-Device-Table-Entry Which Should Be Rejected

Purpose: To verify that the IUT will handle a Delete-Foreign-Device-Table-Entry message when an invalid FDT entry is supplied.

Test Steps:

1. TRANSMIT DESTINATION = IUT, SOURCE = TD,
— ~~Delete Foreign Device Table Entry,~~
— ~~'FDT Entry' = FD2~~
2. RECEIVE, DESTINATION = TD, SOURCE = IUT,
— ~~BVLC-Result,~~
— ~~'Result Code' = Delete Foreign Device NAK~~
3. TRANSMIT DESTINATION = IUT, SOURCE = TD,
— ~~Read Foreign Device Table~~
4. RECEIVE, DESTINATION = TD, SOURCE = IUT,
— ~~Read Foreign Device Table Ack,~~
B/IP address of FD1, Time To Live = 0, Remaining Time = 0

Configuration Requirements: The TD shall take the role of foreign device FD1. The IUT's FDT must be empty.

Test Steps:

1. TRANSMIT
DA = IUT,
SA = FD1,
Register-Foreign-Device,
'Time-To-Live' = 120
2. RECEIVE
DA = FD1,
SA = IUT,
BVLC-Result,
'Result Code' = Successful completion
3. TRANSMIT
DA = IUT,
SA = FD1,
Read-Foreign-Device-Table
4. RECEIVE
DA = FD1,
SA = IUT,
Read-Foreign-Device-Table-Ack,
B/IP address of FD1, Time-To-Live = 120, Remaining-Time = ?
5. TRANSMIT
DA = IUT,
SA = FD1,
Delete-Foreign-Device-Table-Entry,
'FDT Entry' = FD2
6. RECEIVE
DA = FD1,
SA = IUT,
BVLC-Result,
'Result Code' = Delete-Foreign-Device NAK
7. TRANSMIT
DA = IUT,

- SA = FDI,
Read-Foreign-Device-Table
- 8. RECEIVE
 - DA = FDI,
 - SA = IUT,
 - Read-Foreign-Device-Table-Ack,
B/IP address of FDI, Time-To-Live = 120, Remaining-Time = ?

[Change Clause **14.6.6**, p. 469]

[Reason for Change: The test was modified to reference figure 14-1 to be consistent with all the BBMD tests.]

14.6.6 Execute Delete-Foreign-Device-Table-Entry

Purpose: To verify that the IUT will handle a Delete-Foreign-Device-Table-Entry ~~message.~~ *message when a valid FDT entry is supplied.*

Test Steps:

1. TRANSMIT DESTINATION = IUT, SOURCE = TD,
~~— Delete Foreign Device Table Entry,~~
~~— 'FDT Entry' = FDI~~
2. RECEIVE, DESTINATION = TD, SOURCE = IUT,
~~— BVLC Result,~~
~~— 'Result Code' = 0~~
3. TRANSMIT DESTINATION = IUT, SOURCE = TD,
~~— Read Foreign Device Table~~
4. RECEIVE, DESTINATION = TD, SOURCE = IUT,
~~— Read Foreign Device Table Ack,~~
~~— List of FDT Entries~~
5. CHECK(FDT is empty)

Configuration Requirements: The TD shall take the role of foreign device FDI. The IUT's FDT must be empty.

Test Steps:

1. TRANSMIT
 - DA = IUT,
 - SA = FDI,
 - Register-Foreign-Device,
'Time-To-Live' = 120
2. RECEIVE
 - DA = FDI,
 - SA = IUT,
 - BVLC-Result,
'Result Code' = Successful completion
3. TRANSMIT
 - DA = IUT,
 - SA = FDI,
 - Read-Foreign-Device-Table
4. RECEIVE
 - DA = FDI,
 - SA = IUT,
 - Read-Foreign-Device-Table-Ack,
B/IP address of FDI, Time-To-Live = 120, Remaining-Time = ?

5. TRANSMIT
 - DA = IUT,
 - SA = FDI,
 - Delete-Foreign-Device-Table-Entry,
 - 'FDT Entry' = FDI
6. RECEIVE
 - DA = FDI,
 - SA = IUT,
 - BVLC-Result,
 - 'Result Code' = Successful completion
7. TRANSMIT
 - DA = IUT,
 - SA = FDI,
 - Read-Foreign-Device-Table
8. RECEIVE
 - DA = FDI,
 - SA = IUT,
 - Read-Foreign-Device-Table-Ack,
 - No FDT Entries

[Change Clause 14.7, p. 469]

[Reason for Change: These tests were modified to reference figure 14-1 to be consistent with all the BBMD tests. Two-hop distribution tests were added.]

14.7 Broadcast Management (BBMD, Foreign Devices, Local Application)

This group of tests verifies that the IUT will execute all paths of broadcast distribution.

Configuration Requirements: The IUT shall be configured so that BBMD option is on and FDT option is on. ~~The BDT shall contain the following three entries:~~

B/IP Address	Label	Subnet Mask
123.4.5.6:0xBAC0	IUT	255.0.0.0
123.7.8.10:0xBAC4	BBMD4	255.0.0.0
123.7.8.12:0xBAC5	BBMD5	255.255.0.0

The FDT shall contain the following two entries:

B/IP Address	Label	Time To Live
123.5.6.7:0xBAC0	FD1	0
123.5.6.8:0xBAC0	FD2	0

B/IP Address	Time-To-Live
FD1	3600
FD2	3600

Notes to Tester: The remaining time in each foreign device registration must be adequate for the tests to be run to completion before the registration terminates.

[Change Clause 14.7.1, p. 470]

14.7.1 Broadcast Message from Directly Connected IP Subnet

Purpose: To verify that the IUT will correctly forward Original-Broadcast-NPDU messages to IP subnets in its BDT, to foreign devices, and to local applications.

Test Concept: The test device shall broadcast an Original-Broadcast-NPDU message as if it were a node on the same IP subnet as the IUT. The DNET/DADR and SNET/SADR fields in the Network Layer header shall not be present, which represents a local broadcast.

~~Steps 2-5 are the distribution of the Who-Is request to the devices considered to be members of the BACnet network, steps 6-10 are the distribution of the I-Am response from the local application.~~

Test Steps:

- ~~1. TRANSMIT DESTINATION=123.255.255.255:0xBAC0, SOURCE=TD,
—— Original Broadcast NPDU,
—— NPDU = Who-Is~~
- ~~2. RECEIVE DESTINATION=123.255.255.255:0xBAC4, SOURCE=IUT,
—— Forwarded NPDU,
—— Originating Device = TD,
—— NPDU = Who-Is~~
- ~~3. RECEIVE DESTINATION=123.7.255.255:0xBAC5, SOURCE=IUT,
—— Forwarded NPDU,
—— Originating Device = TD,
—— NPDU = Who-Is~~
- ~~4. RECEIVE DESTINATION=FD1, SOURCE=IUT,
—— Forwarded NPDU,
—— Originating Device = TD,
—— NPDU = Who-Is~~
- ~~5. RECEIVE DESTINATION=FD2, SOURCE=IUT,
—— Forwarded NPDU,
—— Originating Device = TD,
—— NPDU = Who-Is~~
- ~~6. RECEIVE DESTINATION=123.255.255.255:0xBAC0, SOURCE=IUT,
—— Original Broadcast NPDU,
—— NPDU = I-Am~~
- ~~7. RECEIVE DESTINATION=123.255.255.255:0xBAC4, SOURCE=IUT,
—— Forwarded NPDU,
—— Originating Device = IUT,
—— NPDU = I-Am~~
- ~~8. RECEIVE DESTINATION=123.7.255.255:0xBAC5, SOURCE=IUT,
—— Forwarded NPDU,
—— Originating Device = IUT,
—— NPDU = I-Am~~
- ~~9. RECEIVE DESTINATION=FD1, SOURCE=IUT,
—— Forwarded NPDU,
—— Originating Device = IUT,
—— NPDU = I-Am~~
- ~~10. RECEIVE DESTINATION=FD2, SOURCE=IUT,
—— Forwarded NPDU,
—— Originating Device = IUT,
—— NPDU = I-Am~~

~~Notes to Tester: The order of the messages transmitted by the IUT is not significant.~~

Configuration Requirements: The TD shall take the role of device D1.

This test is broken into separate tests for one-hop distribution and two-hop distribution.

14.7.1.1 Broadcast Message from Directly Connected IP Subnet (One-hop Distribution)

Configuration Requirements: The IUT's BDT shall contain the following three entries:

<i>B/IP Address</i>	<i>Broadcast Distribution Mask</i>
<i>IUT</i>	<i>IP Subnet 1 subnet mask</i>
<i>BBMD1</i>	<i>IP Subnet 2 subnet mask</i>
<i>BBMD2</i>	<i>IP Subnet 3 subnet mask</i>

Steps 2-5 are the distribution of the Who-Is request to the devices considered to be members of the BACnet network, steps 6-10 are the distribution of the I-Am response from the local application.

Test Steps:

1. TRANSMIT

*DA = Local IP Broadcast,
SA = D1,
Original-Broadcast-NPDU,
NPDU = Who-Is*

2. RECEIVE

*DA = Directed IP Broadcast to IP Subnet 2,
SA = IUT,
Forwarded-NPDU,
Originating-Device = D1,
NPDU = Who-Is*

3. RECEIVE

*DA = Directed IP Broadcast to IP Subnet 3,
SA = IUT,
Forwarded-NPDU,
Originating-Device = D1,
NPDU = Who-Is*

4. RECEIVE

*DA = FD1,
SA = IUT,
Forwarded-NPDU,
Originating-Device = D1,
NPDU = Who-Is*

5. RECEIVE

*DA = FD2,
SA = IUT,
Forwarded-NPDU,
Originating-Device = D1,
NPDU = Who-Is*

6. RECEIVE

*DA = Local IP Broadcast,
SA = IUT,
Original-Broadcast-NPDU,
NPDU = I-Am*

7. RECEIVE

*DA = Directed IP Broadcast to IP Subnet 2,
SA = IUT,
Forwarded-NPDU,
Originating-Device = IUT,
NPDU = I-Am*

8. RECEIVE

*DA = Directed IP Broadcast to IP Subnet 3,
SA = IUT,
Forwarded-NPDU,*

*Originating-Device = IUT,
NPDU = I-Am*

9. *RECEIVE*

*DA = FD1,
SA = IUT,
Forwarded-NPDU,
Originating-Device = IUT,
NPDU = I-Am*

10. *RECEIVE*

*DA = FD2,
SA = IUT,
Forwarded-NPDU,
Originating-Device = IUT,
NPDU = I-Am*

Notes to Tester: The order of the messages transmitted by the IUT is not significant.

14.7.1.2 Broadcast Message from Directly Connected IP Subnet (Two-hop Distribution)

Configuration Requirements: The BDT shall contain the following three entries:

<i>B/IP Address</i>	<i>Broadcast Distribution Mask</i>
<i>IUT</i>	<i>255.255.255.255</i>
<i>BBMD1</i>	<i>255.255.255.255</i>
<i>BBMD2</i>	<i>255.255.255.255</i>

Steps 2-5 are the distribution of the Who-Is request to the devices considered to be members of the BACnet network, steps 6-10 are the distribution of the I-Am response from the local application.

Test Steps:

1. *TRANSMIT*

*DA = Local IP Broadcast,
SA = D1,
Original-Broadcast-NPDU,
NPDU = Who-Is*

2. *RECEIVE*

*DA = BBMD1,
SA = IUT,
Forwarded-NPDU,
Originating-Device = D1,
NPDU = Who-Is*

3. *RECEIVE*

*DA = BBMD2,
SA = IUT,
Forwarded-NPDU,
Originating-Device = D1,
NPDU = Who-Is*

4. *RECEIVE*

*DA = FD1,
SA = IUT,
Forwarded-NPDU,
Originating-Device = D1,
NPDU = Who-Is*

5. *RECEIVE*

*DA = FD2,
SA = IUT,
Forwarded-NPDU,*

- Originating-Device = D1,*
NPDU = Who-Is
6. *RECEIVE*
DA = Local IP Broadcast,
SA = IUT,
Original-Broadcast-NPDU,
NPDU = I-Am
7. *RECEIVE*
DA = BBMD1,
SA = IUT,
Forwarded-NPDU,
Originating-Device = IUT,
NPDU = I-Am
8. *RECEIVE*
DA = BBMD2,
SA = IUT,
Forwarded-NPDU,
Originating-Device = IUT,
NPDU = I-Am
9. *RECEIVE*
DA = FD1,
SA = IUT,
Forwarded-NPDU,
Originating-Device = IUT,
NPDU = I-Am
10. *RECEIVE*
DA = FD2,
SA = IUT,
Forwarded-NPDU,
Originating-Device = IUT,
NPDU = I-Am

Notes to Tester: The order of the messages transmitted by the IUT is not significant.

[Change Clause **14.7.2**, p. 471]

14.7.2 Broadcast Message Forwarded by a Peer BBMD

Purpose: To verify that the IUT will send Forwarded-NPDU messages to the local network, peer BBMDs, foreign devices, and to local applications.

Test Concept: The TD shall transmit a Forwarded-NPDU to the IUT as if it were peer ~~BBMD4~~BBMD1. The DNET/DADR and SNET/SADR fields in the Network Layer header shall not be present, which represents a local broadcast-present.

~~Steps 2-5 are the distribution of the Who-Is request to the devices considered to be members of the BACnet network, steps 6-10 are the distribution of the I-Am response from the local application.~~

Test Steps:

- ~~1. TRANSMIT DESTINATION=IUT, SOURCE=BBMD4,
Forwarded NPDU,
Originating Device = TD,
NPDU = Who-Is~~
- ~~2. RECEIVE DESTINATION=123.255.255.255:0xBAC0, SOURCE=IUT,
Forwarded NPDU,~~

- ~~— Originating Device = TD,~~
- ~~— NPDU = Who-Is~~
- 3. ~~RECEIVE DESTINATION=123.7.255.255:0xBAC5, SOURCE=IUT,~~
- ~~— Forwarded NPDU,~~
- ~~— Originating Device = TD,~~
- ~~— NPDU = Who-Is~~
- 4. ~~RECEIVE DESTINATION=FD1, SOURCE=IUT,~~
- ~~— Forwarded NPDU,~~
- ~~— Originating Device = TD,~~
- ~~— NPDU = Who-Is~~
- 5. ~~RECEIVE DESTINATION=FD2, SOURCE=IUT,~~
- ~~— Forwarded NPDU,~~
- ~~— Originating Device = TD,~~
- ~~— NPDU = Who-Is~~
- 6. ~~RECEIVE DESTINATION=123.255.255.255:0xBAC0, SOURCE=IUT,~~
- ~~— Original Broadcast NPDU,~~
- ~~— NPDU = I Am~~
- 7. ~~RECEIVE DESTINATION=123.255.255.255:0xBAC4, SOURCE=IUT,~~
- ~~— Forwarded NPDU,~~
- ~~— Originating Device = IUT,~~
- ~~— NPDU = I Am~~
- 8. ~~RECEIVE DESTINATION=123.7.255.255:0xBAC5, SOURCE=IUT,~~
- ~~— Forwarded NPDU,~~
- ~~— Originating Device = IUT,~~
- ~~— NPDU = I Am~~
- 9. ~~RECEIVE DESTINATION=FD1, SOURCE=IUT,~~
- ~~— Forwarded NPDU,~~
- ~~— Originating Device = IUT,~~
- ~~— NPDU = I Am~~
- 10. ~~RECEIVE DESTINATION=FD2, SOURCE=IUT,~~
- ~~— Forwarded NPDU,~~
- ~~— Originating Device = IUT,~~
- ~~— NPDU = I Am~~

Notes to Tester: The order of the messages transmitted by the IUT is not significant.

Configuration Requirements: The TD shall take the role of BBMD1.

This test is broken into separate tests for one-hop distribution and two-hop distribution.

14.7.2.1 Broadcast Message Forwarded by a Peer BBMD (One-hop Distribution)

Configuration Requirements: The BDT shall be configured as in test 14.7.1.1.

Steps 2-3 are the distribution of the Who-Is request to the devices considered to be members of the BACnet network, steps 4-8 are the distribution of the I-Am response from the local application.

Test Steps:

1. TRANSMIT
 - DA = Directed IP Broadcast to IP Subnet 1,*
 - SA = BBMD1,*
 - Forwarded-NPDU,*
 - Originating-Device = D2,*
 - NPDU = Who-Is*
2. RECEIVE

- DA = FD1,*
 - SA = IUT,*
 - Forwarded-NPDU,*
 - Originating-Device = D2,*
 - NPDU = Who-Is*
- 3. *RECEIVE*
 - DA = FD2,*
 - SA = IUT,*
 - Forwarded-NPDU,*
 - Originating-Device = D2,*
 - NPDU = Who-Is*
- 4. *RECEIVE*
 - DA = Local IP Broadcast,*
 - SA = IUT,*
 - Original-Broadcast-NPDU,*
 - NPDU = I-Am*
- 5. *RECEIVE*
 - DA = Directed IP Broadcast to IP Subnet 2,*
 - SA = IUT,*
 - Forwarded-NPDU,*
 - Originating-Device = IUT,*
 - NPDU = I-Am*
- 6. *RECEIVE*
 - DA = Directed IP Broadcast to IP Subnet 3,*
 - SA = IUT,*
 - Forwarded-NPDU,*
 - Originating-Device = IUT,*
 - NPDU = I-Am*
- 7. *RECEIVE*
 - DA = FD1,*
 - SA = IUT,*
 - Forwarded-NPDU,*
 - Originating-Device = IUT,*
 - NPDU = I-Am*
- 8. *RECEIVE*
 - DA = FD2,*
 - SA = IUT,*
 - Forwarded-NPDU,*
 - Originating-Device = IUT,*
 - NPDU = I-Am*

Notes to Tester: The order of the messages transmitted by the IUT is not significant.

14.7.2.2 Broadcast Message Forwarded by a Peer BBMD (Two-hop Distribution)

Configuration Requirements: The BDT shall be configured as in test 14.7.1.2

Steps 2-4 are the distribution of the Who-Is request to the devices considered to be members of the BACnet network, steps 5-9 are the distribution of the I-Am response from the local application.

Test Steps:

- 1. *TRANSMIT*
 - DA = IUT,*
 - SA = BBMD1,*
 - Forwarded-NPDU,*

- Originating-Device = D2,*
NPDU = Who-Is
2. *RECEIVE*
DA = Local IP Broadcast,
SA = IUT,
Forwarded-NPDU,
Originating-Device = D2,
NPDU = Who-Is
 3. *RECEIVE*
DA = FD1,
SA = IUT,
Forwarded-NPDU,
Originating-Device = D2,
NPDU = Who-Is
 4. *RECEIVE*
DA = FD2,
SA = IUT,
Forwarded-NPDU,
Originating-Device = D2,
NPDU = Who-Is
 5. *RECEIVE*
DA = Local IP Broadcast,
SA = IUT,
Original-Broadcast-NPDU,
NPDU = I-Am
 6. *RECEIVE*
DA = BBMD1,
SA = IUT,
Forwarded-NPDU,
Originating-Device = IUT,
NPDU = I-Am
 7. *RECEIVE*
DA = BBMD2,
SA = IUT,
Forwarded-NPDU,
Originating-Device = IUT,
NPDU = I-Am
 8. *RECEIVE*
DA = FD1,
SA = IUT,
Forwarded-NPDU,
Originating-Device = IUT,
NPDU = I-Am
 9. *RECEIVE*
DA = FD2,
SA = IUT,
Forwarded-NPDU,
Originating-Device = IUT,
NPDU = I-Am

Notes to Tester: The order of the messages transmitted by the IUT is not significant.

[Change Clause **14.7.3**, p. 472]

14.7.3 Broadcast Message From a Foreign Device

Purpose: To verify that the IUT will send Forwarded-NPDU messages to the local network, peer BBMDs, foreign devices, and to local applications.

Test Concept: The TD shall transmit a Distribute-Broadcast-To-Network to the IUT as if it were foreign device FD1. The DNET/DADR and SNET/SADR fields in the Network Layer header shall not be present, which represents a local broadcast.~~present.~~

~~Steps 2-5 are the distribution of the Who-Is request to the devices considered to be members of the BACnet network, steps 6-10 are the distribution of the I-Am response from the local application.~~

Test Steps:

- ~~1. TRANSMIT DESTINATION=IUT, SOURCE=FD1,
Distribute Broadcast To Network,
Originating Device = FD1,
NPDU = Who-Is~~
- ~~2. RECEIVE DESTINATION=123.255.255.255:0xBAC0, SOURCE=IUT,
Forwarded NPDU,
Originating Device = FD1,
NPDU = Who-Is~~
- ~~3. RECEIVE DESTINATION=123.255.255.255:0xBAC4, SOURCE=IUT,
Forwarded NPDU,
Originating Device = FD1,
NPDU = Who-Is~~
- ~~4. RECEIVE DESTINATION=123.7.255.255:0xBAC5, SOURCE=IUT,
Forwarded NPDU,
Originating Device = FD1,
NPDU = Who-Is~~
- ~~5. RECEIVE DESTINATION=FD2, SOURCE=IUT,
Forwarded NPDU,
Originating Device = FD1,
NPDU = Who-Is~~
- ~~6. RECEIVE DESTINATION=123.255.255.255:0xBAC0, SOURCE=IUT,
Original Broadcast NPDU,
NPDU = I-Am~~
- ~~7. RECEIVE DESTINATION=123.255.255.255:0xBAC4, SOURCE=IUT,
Forwarded NPDU,
Originating Device = IUT,
NPDU = I-Am~~
- ~~8. RECEIVE DESTINATION=123.7.255.255:0xBAC5, SOURCE=IUT,
Forwarded NPDU,
Originating Device = IUT,
NPDU = I-Am~~
- ~~9. RECEIVE DESTINATION=FD1, SOURCE=IUT,
Forwarded NPDU,
Originating Device = IUT,
NPDU = I-Am~~
- ~~10. RECEIVE DESTINATION=FD2, SOURCE=IUT,
Forwarded NPDU,
Originating Device = IUT,
NPDU = I-Am~~

Notes to Tester: ~~The order of the messages transmitted by the IUT is not significant.~~

Configuration Requirements: The TD shall take the role of FD1.

This test is broken into separate tests for one-hop distribution and two-hop distribution.

14.7.3.1 Broadcast Message From a Foreign Device (One-hop Distribution)

Configuration Requirements: The BDT shall be configured as in test 14.7.1.1.

Steps 2-5 are the distribution of the Who-Is request to the devices considered to be members of the BACnet network, steps 6-10 are the distribution of the I-Am response from the local application.

Test Steps:

1. TRANSMIT
DA = IUT,
SA = FD1,
Distribute-Broadcast-To-Network,
NPDU = Who-Is
2. RECEIVE
DA = Local IP Broadcast,
SA = IUT,
Forwarded-NPDU,
Originating-Device = FD1,
NPDU = Who-Is
3. RECEIVE
DA = BBMD1,
SA = IUT,
Forwarded-NPDU,
Originating-Device = FD1,
NPDU = Who-Is
4. RECEIVE
DA = BBMD2,
SA = IUT,
Forwarded-NPDU,
Originating-Device = FD1,
NPDU = Who-Is
5. RECEIVE
DA = FD2,
SA = IUT,
Forwarded-NPDU,
Originating-Device = FD1,
NPDU = Who-Is
6. RECEIVE
DA = Local IP Broadcast,
SA = IUT,
Original-Broadcast-NPDU,
NPDU = I-Am
7. RECEIVE
DA = Directed IP Broadcast to IP Subnet 2,
SA = IUT,
Forwarded-NPDU,
Originating-Device = IUT,
NPDU = I-Am
8. RECEIVE
DA = Directed IP Broadcast to IP Subnet 3,
SA = IUT,
Forwarded-NPDU,

*Originating-Device = IUT,
NPDU = I-Am*

9. *RECEIVE*

*DA = FD1,
SA = IUT,
Forwarded-NPDU,
Originating-Device = IUT,
NPDU = I-Am*

10. *RECEIVE*

*DA = FD2,
SA = IUT,
Forwarded-NPDU,
Originating-Device = IUT,
NPDU = I-Am*

Notes to Tester: The order of the messages transmitted by the IUT is not significant.

14.7.3.2 Broadcast Message From a Foreign Device (Two-hop Distribution)

Configuration Requirements: The BDT and FDT shall be configured as in test 14.7.1.2.

Steps 2-5 are the distribution of the Who-Is request to the devices considered to be members of the BACnet network, steps 6-10 are the distribution of the I-Am response from the local application.

Test Steps:

1. *TRANSMIT*

*DA = IUT,
SA = FD1,
Distribute-Broadcast-To-Network,
NPDU = Who-Is*

2. *RECEIVE*

*DA = Local IP Broadcast,
SA = IUT,
Forwarded-NPDU,
Originating-Device = FD1,
NPDU = Who-Is*

3. *RECEIVE*

*DA = BBMD1,
SA = IUT,
Forwarded-NPDU,
Originating-Device = FD1,
NPDU = Who-Is*

4. *RECEIVE*

*DA = BBMD2,
SA = IUT,
Forwarded-NPDU,
Originating-Device = FD1,
NPDU = Who-Is*

5. *RECEIVE*

*DA = FD2,
SA = IUT,
Forwarded-NPDU,
Originating-Device = FD1,
NPDU = Who-Is*

6. *RECEIVE*

*DA = Local IP Broadcast,
SA = IUT,
Original-Broadcast-NPDU,
NPDU = I-Am*

7. *RECEIVE*

*DA = BBMD1,
SA = IUT,
Forwarded-NPDU,
Originating-Device = IUT,
NPDU = I-Am*

8. *RECEIVE DA = BBMD2,*

*SA = IUT,
Forwarded-NPDU,
Originating-Device = IUT,
NPDU = I-Am*

9. *RECEIVE*

*DA = FD1,
SA = IUT,
Forwarded-NPDU,
Originating-Device = IUT,
NPDU = I-Am*

10. *RECEIVE*

*DA = FD2,
SA = IUT,
Forwarded-NPDU,
Originating-Device = IUT,
NPDU = I-Am*

Notes to Tester: The order of the messages transmitted by the IUT is not significant.

[Insert new Clause **14.X1**, p. 473]

14.X1 Registering as a Foreign Device

Dependencies: None

Purpose: This test case verifies that the IUT can register as a foreign device with a BBMD.

BACnet Reference Clause: J.5.2

Test Concept: The IUT is caused to register as a foreign device with the TD.

Configuration Requirements: The IUT is configured to register as a foreign device with the TD.

Test Steps:

1. RECEIVE DESTINATION = TD, SOURCE = IUT,
Register-Foreign-Device

[Insert new Clause **14.X2**, p. 473]

14.X2 Initiating BVLL Service Requests Conveying an NPDU

This group of tests verifies that the IUT can correctly initiate BVLL service requests conveying an NPDU.

14.X2.1 Distribute-Broadcast-To-Network

Dependencies: 14.X1, "Registering as a Foreign Device"

Purpose: This test case verifies that the IUT, registered as a foreign device, can issue a request to a BBMD to broadcast the message on all subnets in the BBMD's BDT.

BACnet Reference Clause: J.2.10

Test Concept: The IUT is configured to register itself as a foreign device with the TD, then after registration is achieved it is caused to initiate a broadcast message to be conveyed to the BBMD for distribution. If the IUT does not support foreign device registration, or cannot initiate broadcast messages conveying a BACnet NPDU, then this test shall be omitted.

Test Steps:

1. RECEIVE DESTINATION = TD, SOURCE = IUT,
Register-Foreign-Device
2. TRANSMIT DESTINATION = IUT, SOURCE = TD,
BVLC-Result,
'Result Code' = Successful completion
3. MAKE (the IUT initiate a broadcast)
4. RECEIVE DESTINATION = TD, SOURCE = IUT,
Distribute-Broadcast-To-Network

14.X2.2 Initiating An Original-Unicast-NPDU

Dependencies: 14.2.3, "Execute Original-Unicast-NPDU"

Purpose: This test case verifies that the IUT can issue a directed NPDU to another device.

BACnet Reference Clause: J.2.11

Test Concept: The TD sends a ReadProperty-Request to the IUT in an Original-Unicast-NPDU. The IUT responds with a ReadProperty-ACK in an Original-Unicast-NPDU.

Test Steps: The test steps for this test are identical to those in 14.2.3, "Execute Original-Unicast-NPDU."

14.X2.3 Original-Broadcast-NPDU

Purpose: This test case verifies that the IUT can issue a broadcast on its own IP subnet.

BACnet Reference Clause: J.2.12

Test Concept: The IUT is caused to initiate a broadcast message on its IP subnet. If the IUT cannot initiate a broadcast message conveying a BACnet NPDU, then this test shall be omitted.

Test Steps:

1. MAKE (the IUT initiate a broadcast)
2. RECEIVE DESTINATION = Local IP Broadcast, SOURCE = IUT,
Original-Broadcast-NPDU